

Double check valve pilot-operated, sandwich type Z2S10

NS 10 | p_{max} 35 MPa | Q_{max} 120 dm³/min | WK 435 920



DATA SHEET - OPERATION MANUAL

APPLICATION

Double check valve, pilot operated, sandwich type Z2S10... is used for cutting off oil flow in one direction (with a possibility of controlling its opening) and opening free flow in the opposite direction. The valve is usually used for:

- unloading the valve that is under pressure
- preventing load drop in the event of a circuit break
- preventing creep movements of the blocked receivers.

The valve is used for sandwich mounting (inter-plate) in any working position.

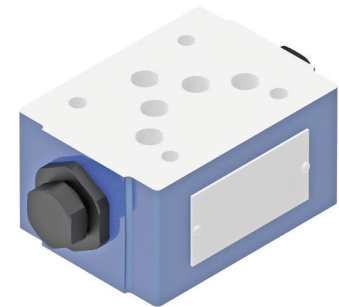

EXAMPLE OF APPLICATION

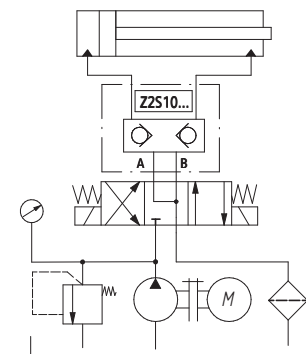
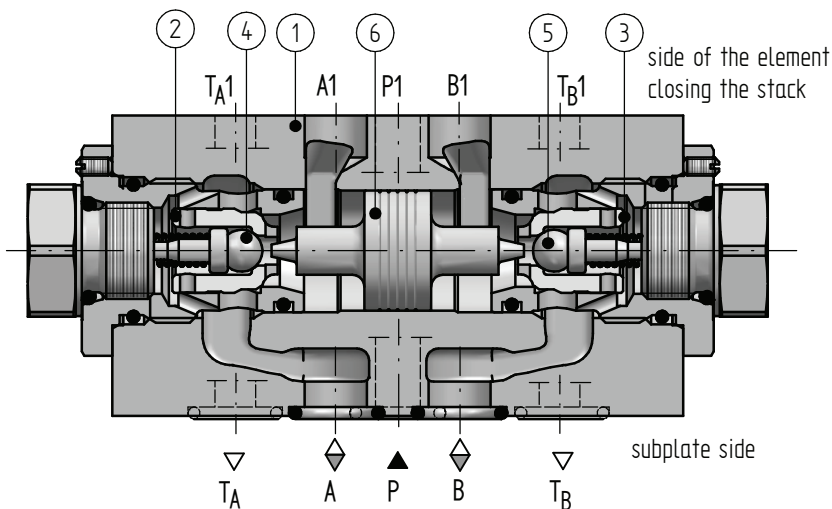

DESCRIPTION OF OPERATION

Double check valve, pilot-operated type **Z2S10...** was made by fitting into one body **1** two pilot-operated check valves **2** and **3** equipped with pre-opening ball valves **4** and **5**. In the direction of flow from **A1** to **A** or **B1** to **B** there is a free flow, but from **A** to **A1** or **B** to **B1**, the flow is closed. If there is a flow in the valve e.g. from **A1** to **A**, the piston **6** is moved to the right and pushes the pre-opening ball **5** from its seat, and then the main poppet **3**.

The connection from **B** to **B1** is then open. The valve operates in a similar way at flow from **B1** to **B**. Application of pre-opening ball valve causes initial, throttled expansion of the pressurised fluid, which prevents the occurrence of strokes/shocks during control. Pressure loss in lines **A1** or **B1** causes both valves to close. In order to obtain a safe and tight closure of both valves, the **A1** and **B1** lines must be connected with the drain.

TECHNICAL PARAMETERS

hydraulic fluid	mineral oil	max. working pressure	35 MPa
required fluid cleanliness class	ISO 4406 class 20/18/15	cracking pressure	0,15 MPa
nominal fluid viscosity	37 mm ² /s at temp. 55°C	area ratio (valve surface / piston surface)	2,68
viscosity range	2,8 ÷ 380 mm ² /s	area ratio (ball seat surface / piston surface)	13,4
fluid temperature range (in tank)	recommended: 40÷55°C max. -20 ÷ 70°C	weight	3 kg
ambient temperature range	-30 ÷ 80°C		

assembly and operation requirements at: www.operating-conditions.ponar.pl

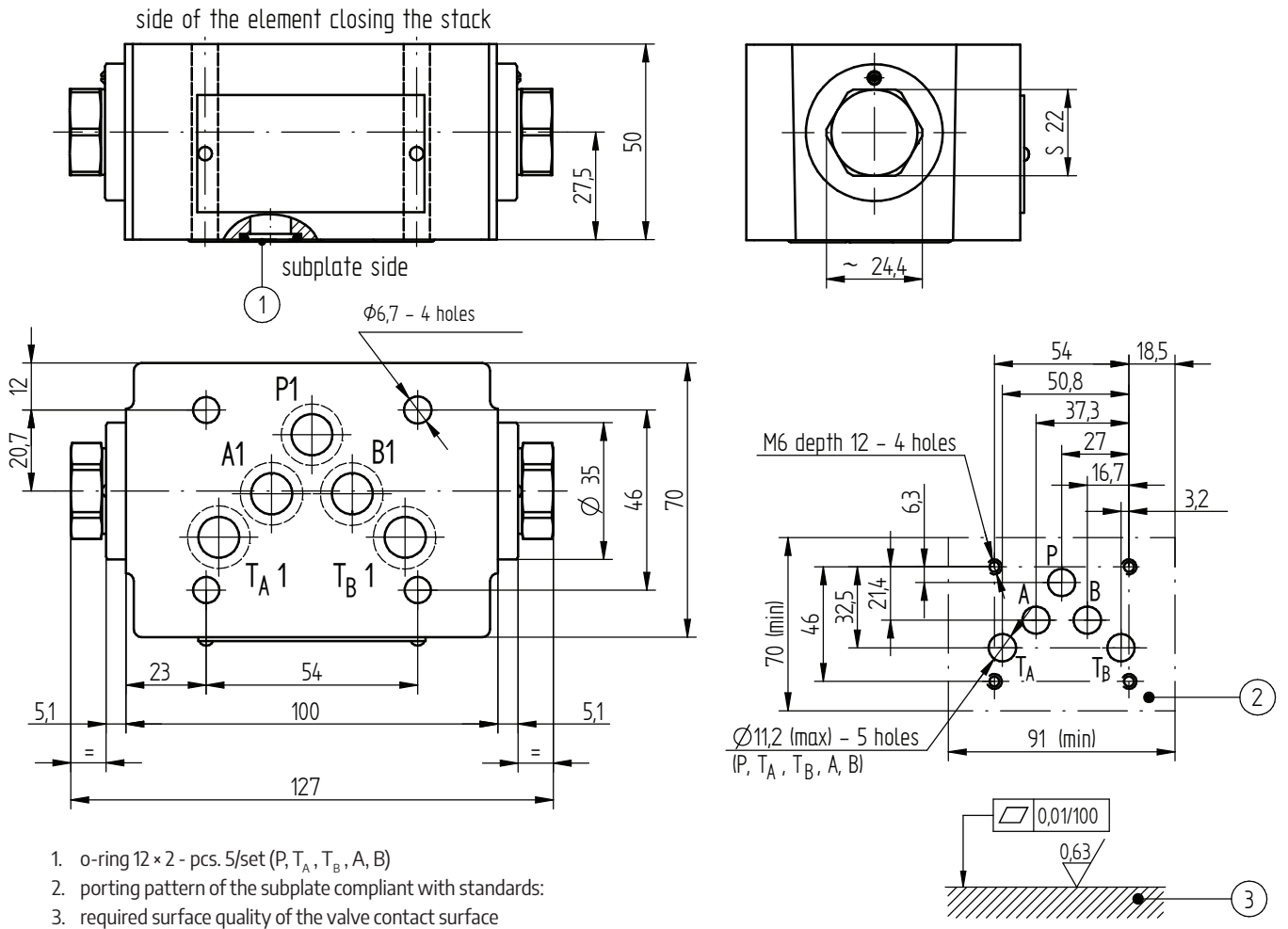

1. o-ring 12 × 2 - pcs. 5/set (P, T_A, T_B, A, B)
2. porting pattern of the subplate compliant with standards:
3. required surface quality of the valve contact surface

HYDRAULIC DIAGRAMS

graphical symbols of the version Z2S10...

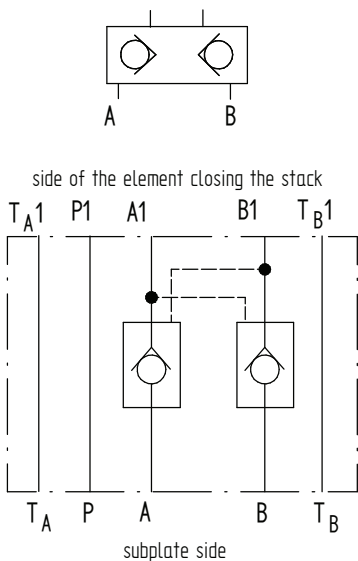

PERFORMANCE CURVES

for fluid viscosity $\nu = 41 \text{ mm}^2/\text{s}$ and temperature $t = 50^\circ\text{C}$

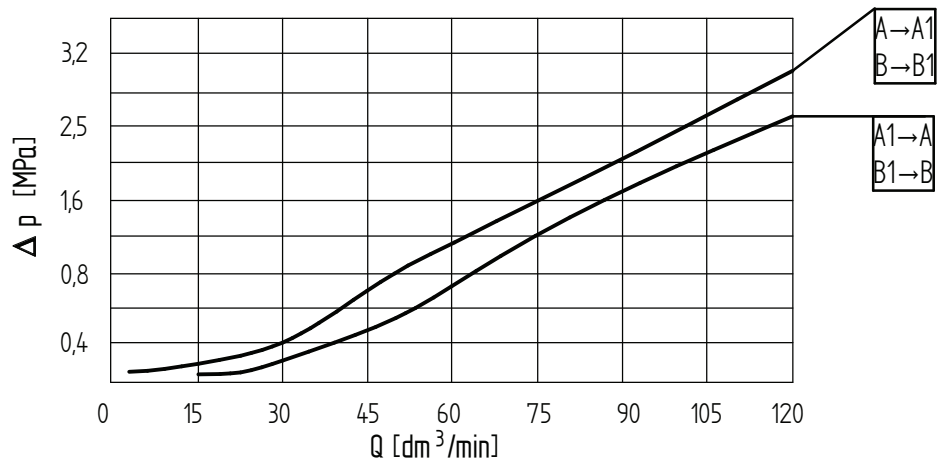

HOW TO ORDER

Z2S 10 – 22 / 15 *

1
2
3
4

<p>1 nominal size (NS)</p> <p>NS10 = 10</p>	<p>2 series number</p> <p>series 22 = 22</p> <p>(20-29) connection and installation dimensions unchanged</p>	<p>3 cracking pressure of check valve</p> <p>0,15 MPa = 15</p>	<p>4 further requirements = *</p> <p>(to be agreed upon with the Manufacturer)</p>
---	--	--	---

Coding example: **Z2S10-22/15**

SUBPLATES AND MOUNTING SCREWS

Subplates should be ordered according to data sheet **WK 496 520**:

G 67/01 - threaded connections G ½

G 534/01 - threaded connections G ¾

NOTE:

The **symbols in bold** are the preferred versions available in short delivery time.

Subplates and mounting screws for mounting the valve **M6 × L*** - 10,9 acc. to **PN - EN ISO 4762 (PN/M-82302)**
4 pcs./set **delivered on separate order.**

Tightening torque of the screws **M_d = 15 Nm.**

NOTE:

(*) - required length of the screws L is related to type and the number of hydraulic components mounted under and over the sandwich plate valve

CONTACT

PONAR Wadowice S.A.
ul. Wojska Polskiego 29
34-100 Wadowice
Poland

tel. +48 33 488 21 00
www.ponar-wadowice.pl

CONTACT

PONAR Wadowice S.A.
ul. Wojska Polskiego 29
34-100 Wadowice
Poland

tel. +48 33 488 21 00
www.ponar-wadowice.pl