

Check valve cartridge are used in hydraulic systems, where free flow in one direction and self-acting closure in the opposite direction are required. These valves can be applied as low-pressure overflow valves for keeping pressure drop at a constant level.

Valves can be installed in any desired position in special seats.

Sealing of interfaces is provided by O-rings which are included.



DESCRIPTION OF OPERATION

The plug 2 being simultaneously the seat for the spring is mounted in the sleeve 1. The spring pushes the poppet 3 onto the internal edge of the sleeve. If a pressure difference in port A exceeds the cracking pressure determined by the spring, the poppet will move along allowing free flow from port A to B.

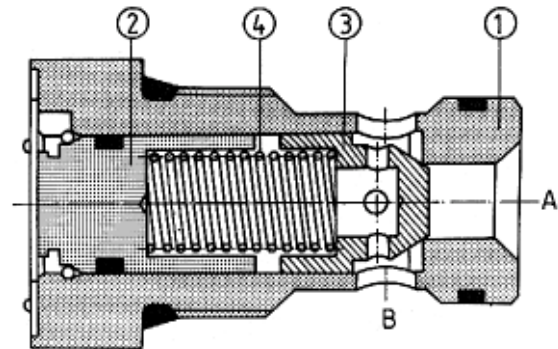

TECHNICAL DATA

Hydraulic fluid	Mineral oil or phosphate ester
Nominal fluid viscosity	37 mm ² /s at the temperature of 328 K
Viscosity range	2.8 to 380 mm ² /s
Optimum working temperature (fluid in a tank)	313 - 328 K
Fluid temperature range	243 - 343 K
Required fluid filtration	16 μm
Recommended fluid filtration	10 μm
Maximum working pressure	32 MPa
Cracking pressure	0.05; 0.1; 0.15 MPa
Weight	0.2 kg

OVERALL DIMENSIONS

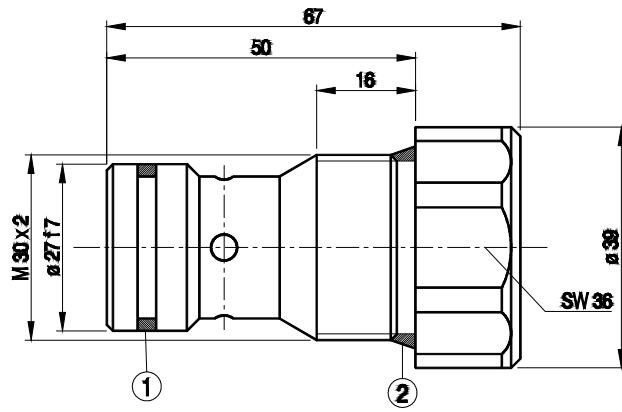

item 1 - o-ring 22.3 × 2.4 - 1 piece
 item 2 - o-ring 26.2 × 3 - 1 piece

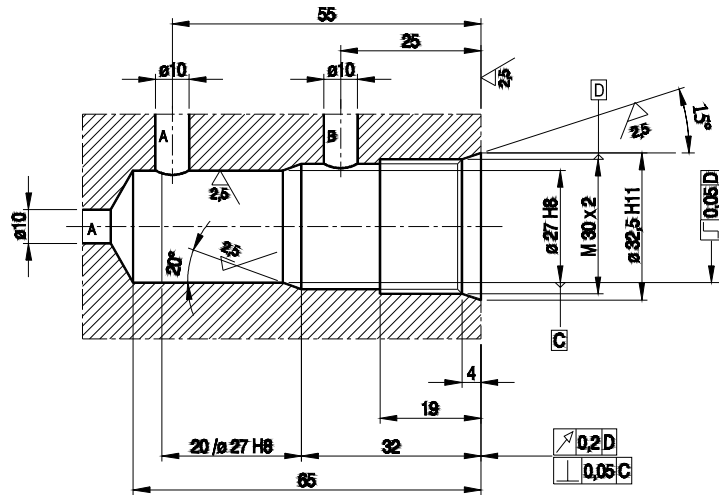

Seat dimensions (torque for tightening the valve - 100 Nm)

PERFORMANCE CURVES, measured at $v = 41 \text{ mm}^2/\text{s}$ and $T = 323 \text{ K}$

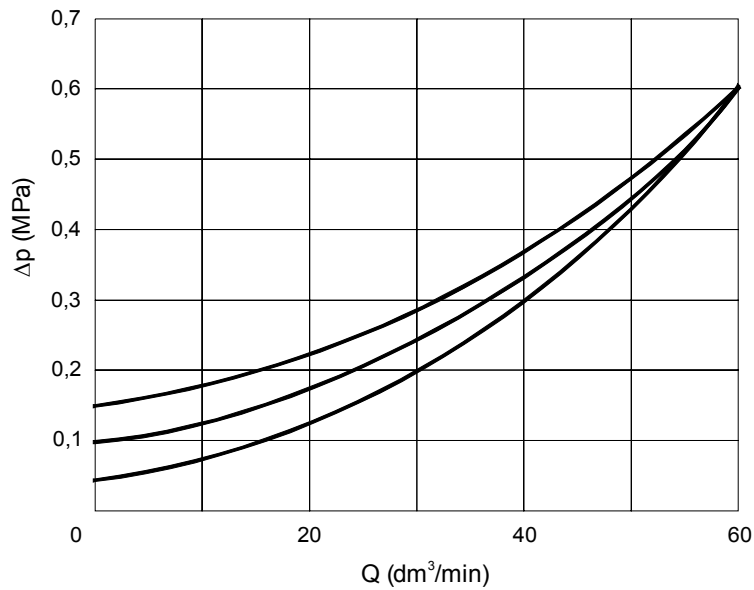

SCHEME

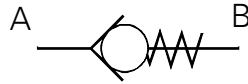

Graphical symbol

HOW TO ORDER

Orders coded in the way showed below should be forwarded to the manufacturer.

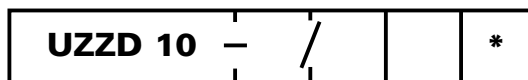

Series number :

11 = 11
(10-19) - installation and connection
dimensions unchanged

Additional requirements in clear text
(to be agreed with the manufacturer)

Cracking pressure

Cracking pressure 0.05 MPa = 05
Cracking pressure 0.10 MPa = 10
Cracking pressure 0.15 MPa = 15

Sealing

Fluids on mineral oil base = no designation
Fluids on phosphate ester base = V

Coding example : UZZD 10 - 11/05

PONAR WADOWICE S.A.
ul. Wojska Polskiego 29
34-100 Wadowice
tel. 033/ 823 39 43, 823 30 41
fax 033/ 873 48 80
e-mail: ponar@ponar-wadowice.pl

